

BROADBAND RECEIVER

BBR SERIES SINGLE CHANNEL

The BBRA and BBTB series broadband receiver provides real-time reception and decoding of any of the 63 VHF or UHF modulated frequencies generated by *ATE's* broadband series transmitters. All outputs are buffered and appear as a single 75 ohm termination. This series is capable of single or multi-drop installation configurations. A simple press of a button achieves channel programming retention.

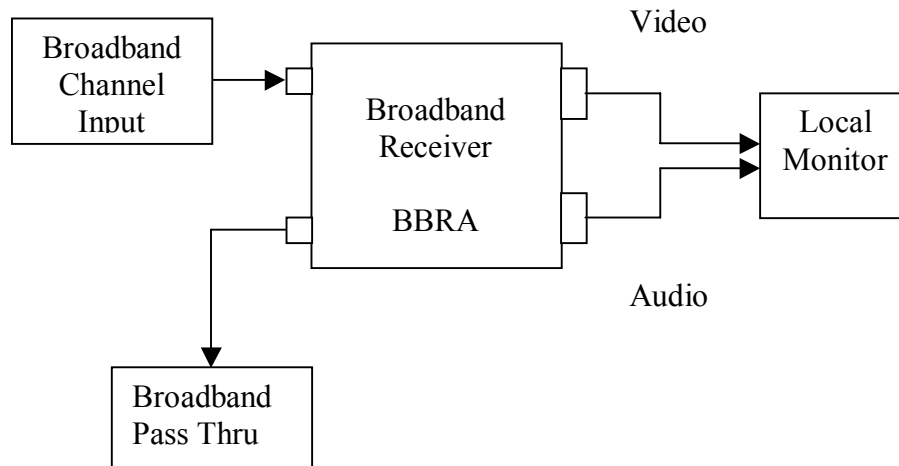

Features & Benefits

Easy to read Digital Display	Direct connect or multi-drop installation
Synthesizer based channel control	Touch button channel selection
Buffered video & audio output	Touch button channel memory save
Built-in self test	Broadcast video and audio **

Specifications: Input: 1 RF Port (BNC) Output: Video (RCA), Audio (RCA)
Power: 15 VDC Pass Through: 1 RF Port (BNC)

** audio on BBRA model only